



DEGSON ELECTRONICS CO., LTD.

Product Specification



in the course of application

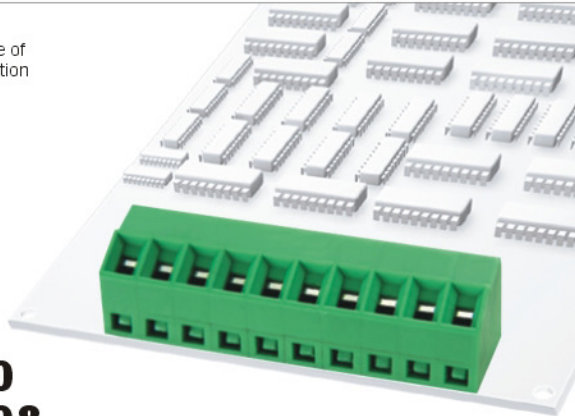

DG127S-5.0
DG127S-5.08

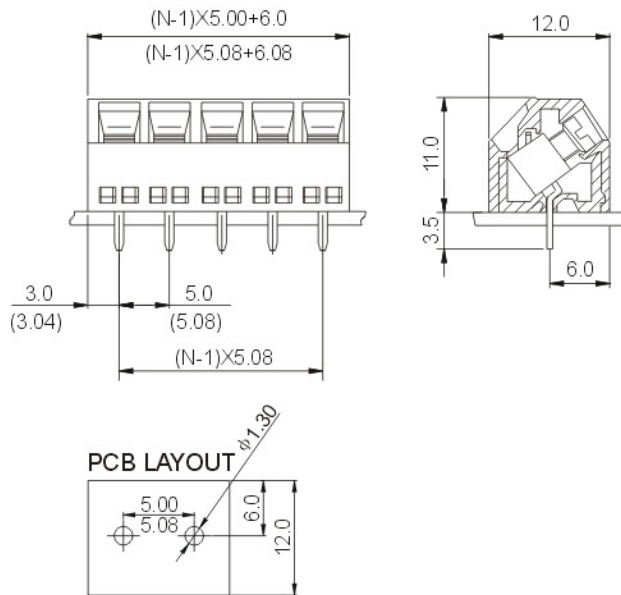

Approval	in the course of application	
Electrical		
Standard	UL	IEC
Rated voltage	300V	250V
Rated current	12A	15A
Wire range	26-16AWG	0.2-1.5mm ²
With standing voltage	AC2000V/1Min	

Mechanical		
Torque	0.4Nm(3.5Lb-In.)	
Ambient temperature	-40°C~+105°C	
Strip length	6mm	
Dimensions		
Pitch	5.0mm(.197")/5.08mm(.200")	
Poles	2P,3P-24P	

Material		
Housing	PA66, UL94V-0	
Screws	M2.5, steel, Cr ³⁺ Zn plated	
Pin header	Brass, Tin plated	
Cage	Brass, Ni plated	

HOW TO ORDER

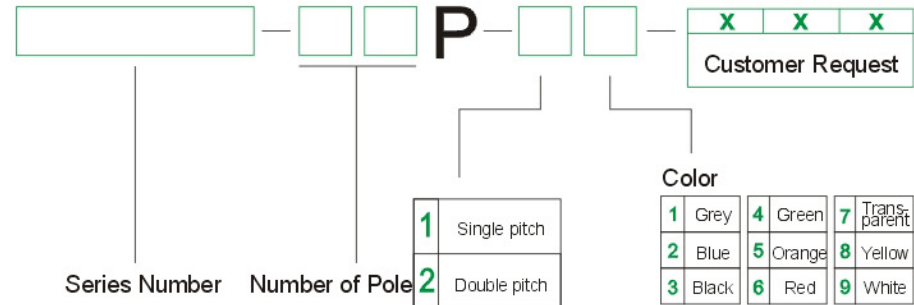

 	 DEGSON ELECTRONICS CO., LTD. NAME DG127S-5.0 DG127S-5.08
------	---