

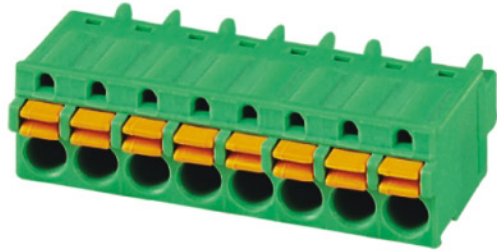

DEGSON ELECTRONICS CO., LTD.

Product Specification



15EDGKN-3.5

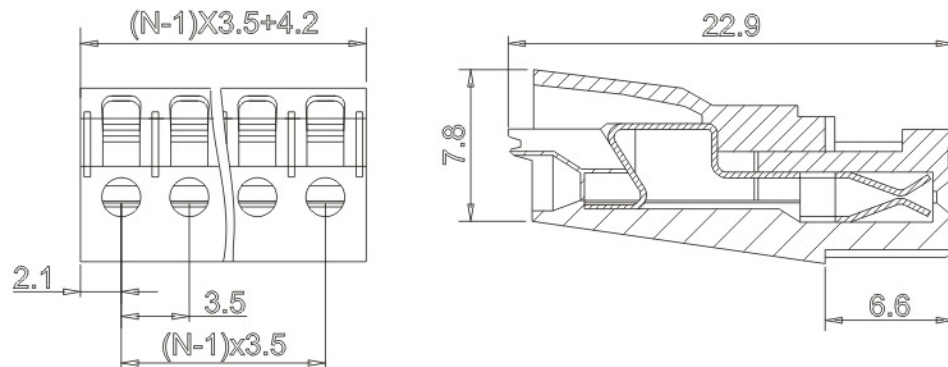

Approval		
Electrical		
Standard	UL	IEC
Rated voltage	300V	250V
Rated current	8A	7A
Wire range	28-16AWG	0.5-1.5mm ²
With standing voltage	AC2000V/1Min	
Mechanical		
Ambient temperature	-40°C~+105°C	
Strip length	7mm	
Dimensions		
Pitch	3.5mm(.138")	
Poles	2P-24P	
Material		
Housing	PA66, UL94V-0	
Contact	Phosphor bronze	
Wire guard	Stainless steel	

HOW TO ORDER

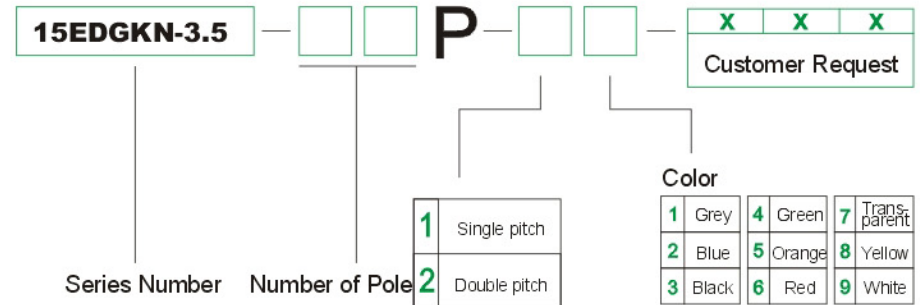

 MM (INCH)	 DEGSON ELECTRONICS CO., LTD.
 THIRD ANGLE PROJECTION	NAME 15EDGKN-3.5