

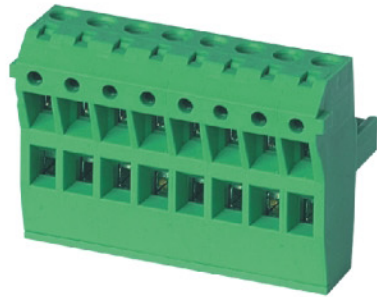

DEGSON ELECTRONICS CO., LTD.

Product Specification



2EDGKH-5.08

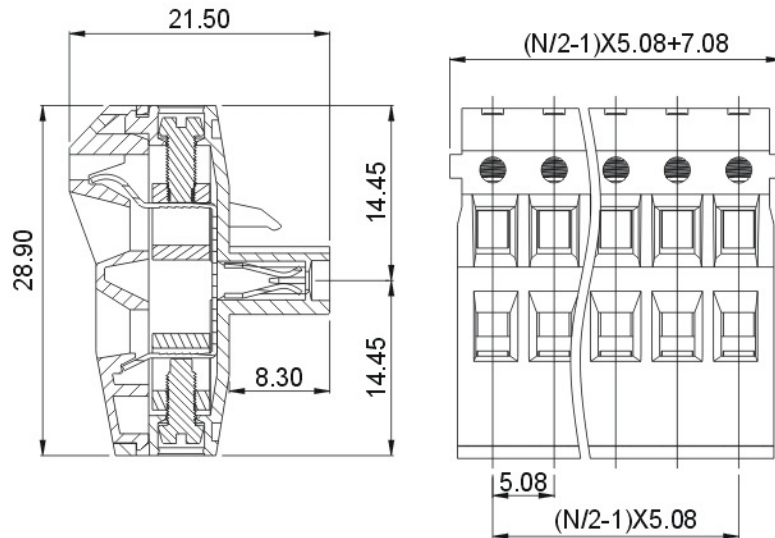

Approval		
Electrical		
Standard	UL	IEC
Rated voltage	300V	320V
Rated current	10A	15A
Wire range	28-12AWG	2.5mm ²
With standing voltage	AC2500V/1Min	

Mechanical	
Torque	0.4N.m(3.5Lb-In.)
Ambient temperature	-40°C~+105°C
Strip length	10mm
Dimensions	
Pitch	5.08 mm(.200")
Poles	2P-12P

Material	
Housing	PA66, UL94V-0
Screws	M2.5, steel, Cr ³⁺ Zn plated
Contact	Phosphor bronze
Cage	Brass, Ni plated

HOW TO ORDER

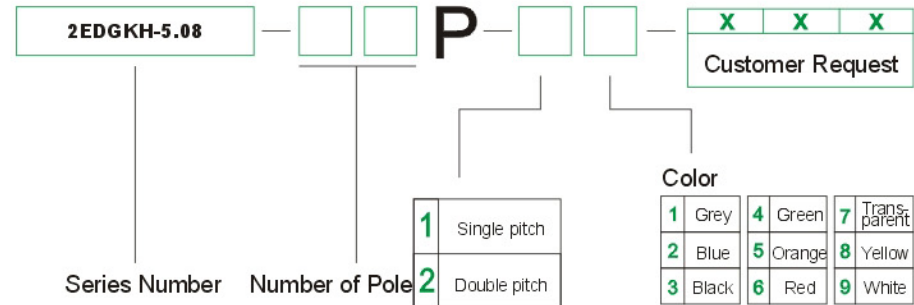

 	DEGSON ELECTRONICS CO., LTD.
NAME	2EDGKH-5.08